

4-side Planer/Moulder

CKM[®]
Quality & Service

CHENG KUANG WOOD MACHINERY WORKS CO., LTD.

■ NO.387, Shoei Yuan Rd., Feng Yuan, Taichung, Taiwan.
Tel: 886-4-2524 1105~7 Fax: 886-4-2527 5507

■ NO.6-10, Shen Chin Rd., Ching Shui, Taichung County, Taiwan.
Tel: 886-4-2620 1763 Fax: 886-4-2620 3763

<http://www.ckmtw.com.tw> E-mail: ckmmail@ckmtw.com.tw

M-412 (Three Phase)

M-410 (Three Phase)

M-410S (Single Phase)

**An Economical Choice for
4-side Moulding**

CHENG KUANG WOOD MACHINERY WORKS CO., LTD.

4-side Planer/Moulder

DESIGNED FOR

- Farm working shop
- School shop
- Hobby
- Small furniture factory



**M-410
M-410S**

- Extremely compact construction**
- Great moulding / planing capacity**
- Extremely flexible performance**
- Affordable price**

All these can be found on **NEW CKM 4-side planer / moulder.**



M-412

4-side Planer/Moulder

M-412 (Three Phase Motor)

Powered Table Elevation

OUTSTANDING FEATURES:

- Three phase motor drive.
- Powerful motor drive for each spindle.
- Digital position control for accurate and easy setting.
- 7,000 rpm high spindle speed.
- Compact construction. Maximum stability.
- Variable feed speed.
- See-thru top guard.

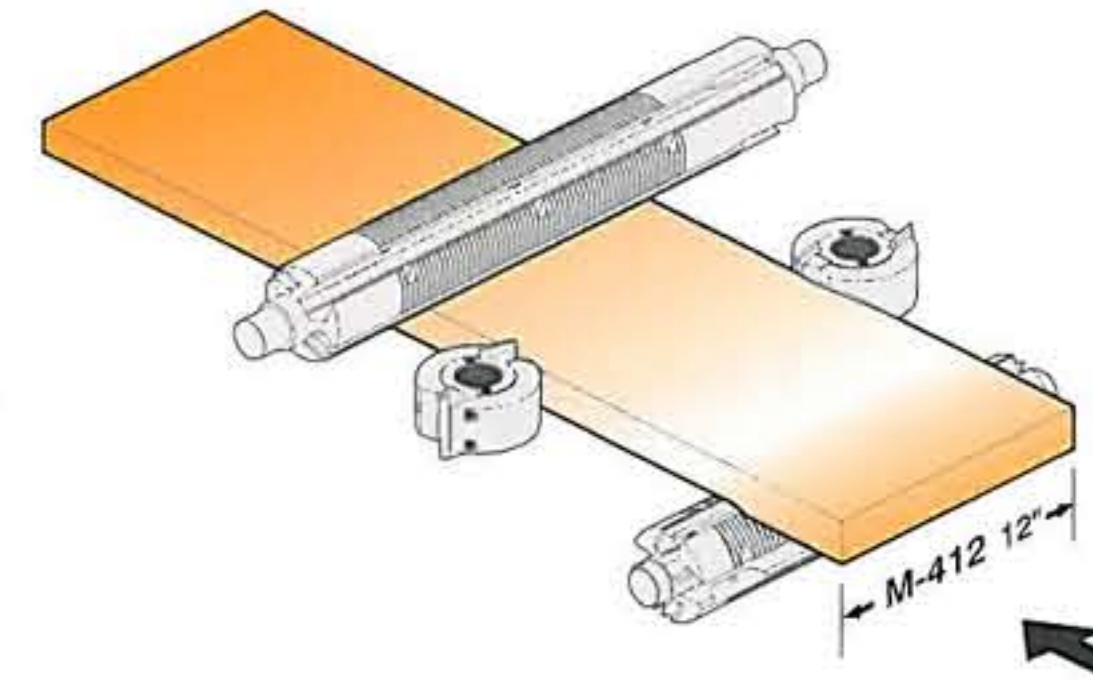

FOUR CUTTERHEADS LAYOUT

- Max. Working width 12" (300mm)
- Max. Profile depth 3/4" (9mm)

GREAT CAPACITY :

- Planing 13"(W) x 9"(D).
- 2-side planing / moulding 13-5/8"(W) x 9"(D).
- 4-side planing / moulding 12"(W) x 4"(D).



CENTRALIZED CONTROL PANEL

- All motion controls of the machine are centralized on the control panel, located at the left side of the machine for easy access and operation convenience.
- Each cutterhead is individually controlled on the control panel.



MANUAL TABLE ELEVATION

- The entire table can be raised or lowered by manually turning a lever through worm gear transmission for effortless elevation.
- Equipped with a mechanical meter for accurate reading of table adjustment amount.



TOP HORIZONTAL SPINDLE

Equipped with two planer knives and two pattern knives for planing and moulding operations at a time.



LEFT VERTICAL SPINDLE ADJUSTMENT

- The left vertical spindle can be adjusted in forward and backward direction to suit workpiece width.
- A front mounted mechanical meter is equipped for convenient and accurate reading of the spindle adjustment amount.



Feed Speed Change Knob With Indicator

VARIABLE FEED SPEED

- Variable feed speed is achieved through a disco type variable speed unit combined with gear reducer, making this moulder ideal for cutting soft and hard wood material.
- Variable feed speed range is 11-52 feet per minute.

4-side Planer/Moulder



EFFICIENT DUST SUCTION DESIGN

The dust suction mechanisms for the right and left spindle are specially designed to achieve better suction performance.



ADDITIONAL OUTFEED FENCE

An adjustable outfeed fence is provided at the outfeed end of the table. This additional fence ensures straight outfeed of wood especially when cutting short wood.



TABLE ELEVATION LIMIT SWITCHES

The table raising and lowering limit are controlled by top and bottom limit switches to avoid accident of over-travel.



DEPENDABLE CONTROL CIRCUIT

- The control circuit inside the electric cabinet consists of high quality electronic components, that assures dependable control and long service life.
- Control circuit meets CE standard is available upon request.

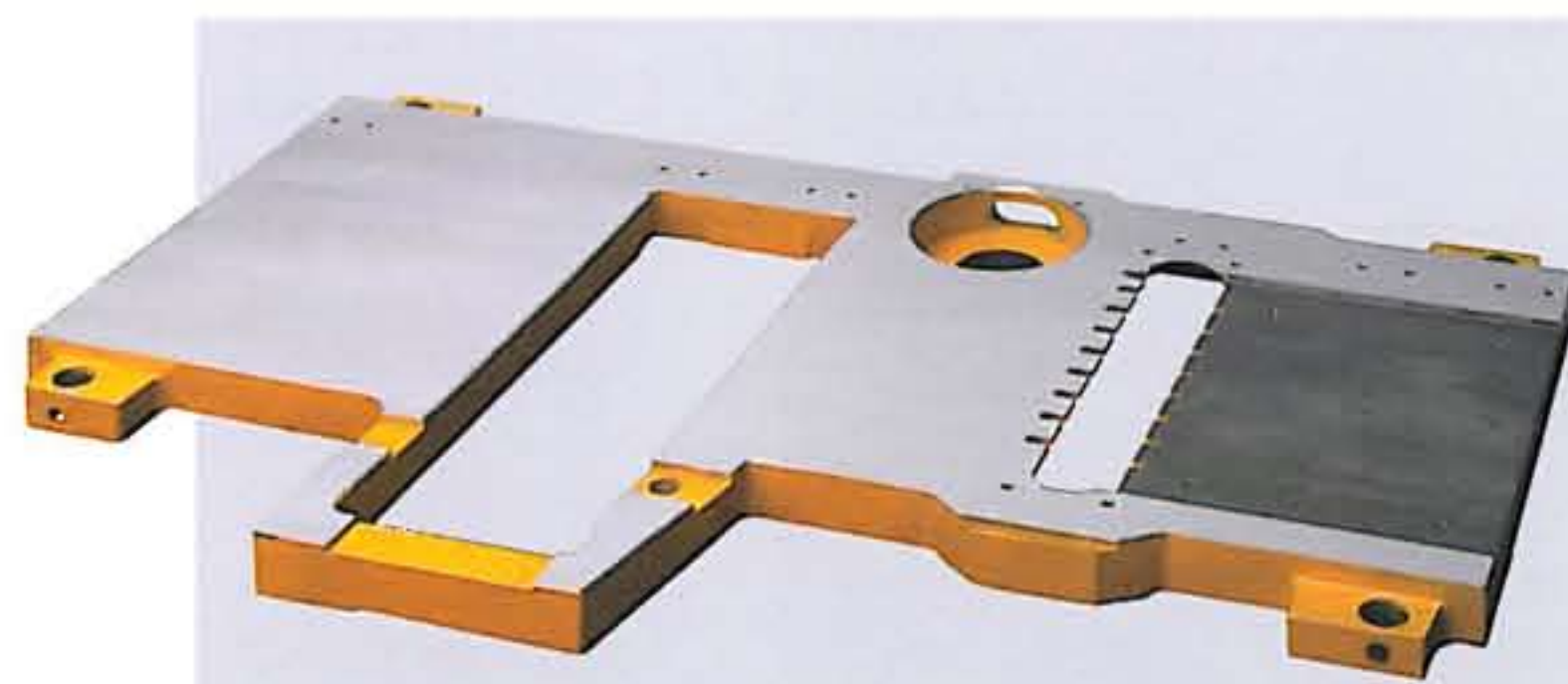

INFEED FENCE (OPTIONAL)

- The infeed fence is extruded from aluminum alloy and anode treated for durability.
- standard length of infeed fence is 1250mm.

Durable Table

- The table is manufactured from high quality cast iron and scientifically rib reinforced without deformation.
- The table surface are hard-chrome plated and precision ground for maximum wear resistance.

INFEED AND OUTFEED TABLE EXTENSION (OPTIONAL)

- The moulder is available to equip with table extensions at infeed and outfeed end. They provide solid support for big wood.
- The in feed and outfeed table are made of steel plate. Each one measures 1210mm(L)x317mm(W) on model M-410, and 1210mm(L)x362mm(W) on model M-412.

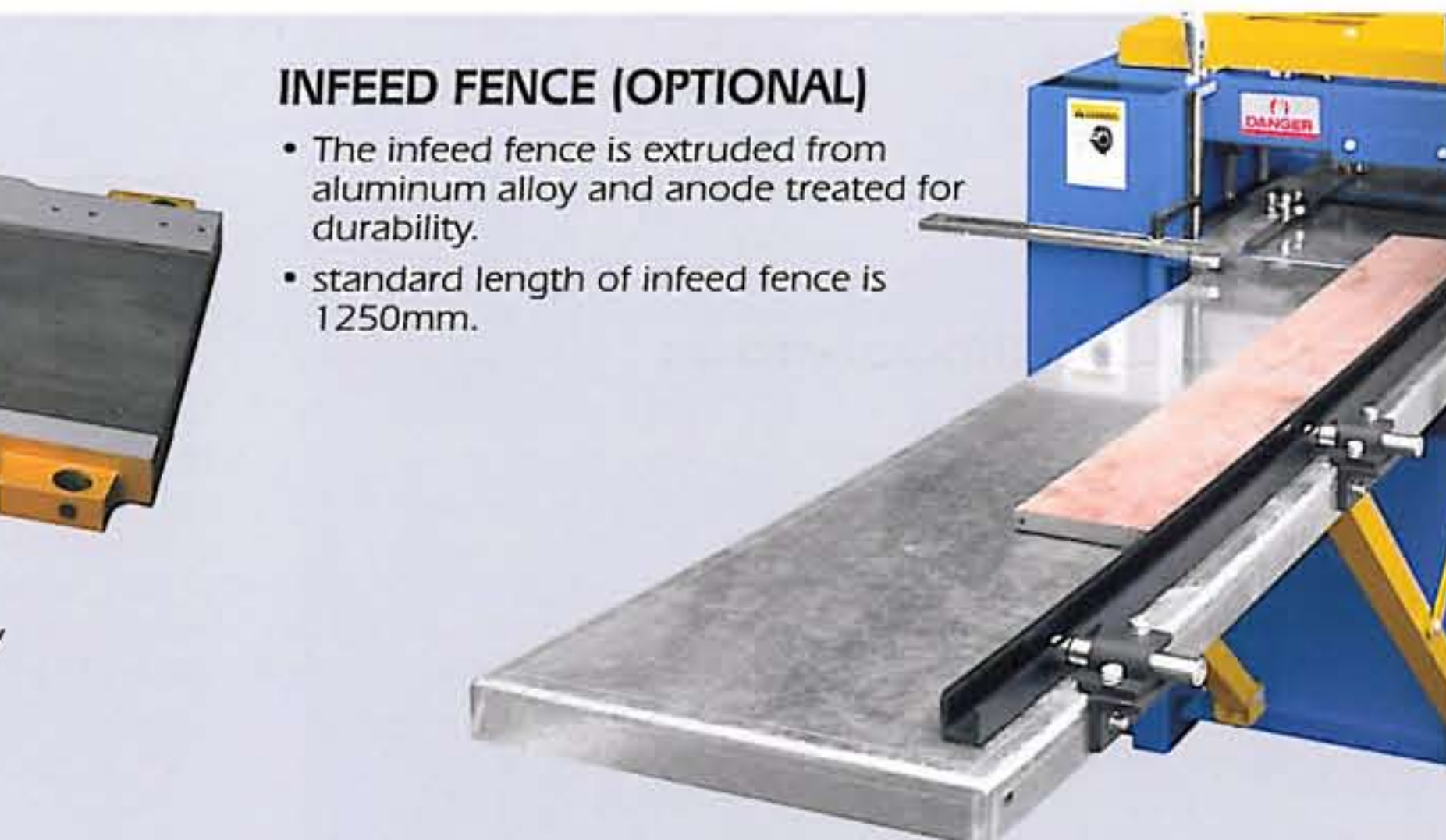

SECIFICATONS :

MODEL	M-412 (Three Phase)	M-410 (Three Phase)	M-410S (Single Phase)
PLANING			
Width	13" (365 mm)	11-5/8" (320 mm)	11-5/8" (320 mm)
Depth	7/16"~9" (12~230 mm)	7/16"~9" (12~230 mm)	7/16"~9" (12~230 mm)
2-SIDE PLANING/MOULDING			
Width	13-5/8"(346 mm)	11-3/4" (300 mm)	11-3/4" (300 mm)
Depth	7/16"~9" (12~230 mm)	7/16"~9" (12~230 mm)	7/16"~9" (12~230 mm)
4-SIDE PLANING/MOULDING			
Width	0~12" (0~306mm)	0~10-1/4" (0~260 mm)	0~10-1/4" (0~260 mm)
Depth	7/16"~4" (12~100mm)	7/16"~4" (12~100 mm)	7/16"~4" (12~100 mm)
TOP HORIZONTAL SPINDLE			
Width	17-15/16"(455 mm)	16"(410 mm)	16"(410 mm)
Max. moulding depth	3/4" (19 mm)	3/8" (10 mm)	3/8" (10 mm)
Max. planing depth	5/16" (8 mm)	5/16" (8 mm)	5/16" (8 mm)
Speed	7000 R.P.M.	7000 R.P.M.	7000 R.P.M.
Cutterhead diameter	2-3/4" (72 mm)	2-27/32" (72 mm)	2-27/32" (72 mm)
Motor	7-1/2 HP (5.5 Kw) x 1	4.1 HP (3 Kw) x 1	3 HP (2.2 Kw) x 1
BOTTOM HORIZONTAL SPINDLE			
Width	13-5/8"(346 mm)	12"(300 mm)	12"(300 mm)
Max. moulding depth	3/16" (5 mm)	3/16" (5 mm)	3/16" (5 mm)
Max. planing depth	1/4" (6 mm)	5/32" (4 mm)	5/32" (4 mm)
Speed	7000 R.P.M.	7000 R.P.M.	7000 R.P.M.
Cutterhead diameter	2-3/4" (72 mm)	2-27/32" (72 mm)	2-27/32" (72 mm)
Motor	5 HP (3.7 Kw) x 1	4.1 HP (3 Kw) x 1	3 HP (2.2 Kw) x 1
RIGHT & LEFT VERTICAL SPINDLES			
Max. cutting height	4" (100 mm)	4" (100 mm)	4" (100 mm)
Max. cutting depth	13/16" (21 mm)	13/16" (21 mm)	13/16" (21 mm)
Spindle diameter	1-1/4" (31.75 mm)	1-1/4" (31.75 mm)	1-1/4" (31.75 mm)
Max. cutter head diameter	51/2" (140 mm)	51/2" (140 mm)	51/2" (140 mm)
Speed	7000 R.P.M.	7000 R.P.M.	7000 R.P.M.
Cutterhead diameter	3-1/2" (90 mm)	3-1/2" (90 mm)	3-1/2" (90 mm)
Motor	4.1 HP (3 Kw) x 2	4.1 HP (3 Kw) x 2	3 HP (2.2 Kw) x 2
TABLE			
Area	1125 x 685 mm	1030 x 630 mm	1030 x 630 mm
Elevation	230 mm	230 mm	230 mm
Power table (raise)	120 w x 1	-	-
FEED SYSTEM			
Speed (variable)	11-52 ft/min.	11-52 ft/min.	11-52 ft/min.
Motor	1/2 HP (0.375 Kw) x 1	1/2 HP (0.375 Kw) x 1	1/2 HP (0.375 Kw) x 1
DUST HOOD OUTLET			
	4" (101.6mm) x 4	4" (101.6mm) x 4	4" (101.6mm) x 4
MACHINE SIZE			
Machine dimensions (L x W x H) mm	1485 x 1265 x 1216 mm	1375 x 1080 x 1210	1375 x 1080 x 1210
Packing dimensions (L x W x H) mm	1350 x 1140 x 1130 mm	1230 x 1080 x 1130	1230 x 1080 x 1130
Net weight	635 kgs (1400lbs)	525 kgs (1157 lbs)	525 kgs (1157 lbs)
Gross weight	730 kgs (1610lbs)	620 kgs (1366 lbs)	620 kgs (1366 lbs)

• Specifications and design characteristics are subject to change without prior notice.

Optional Accessories:

For Increasing Operational Convenience

VERTICAL SPINDLE CUTTER (Optional)

- Cutter height range 38 and 100mm (1/2" and 4").
- Choice of two cutter configuration.

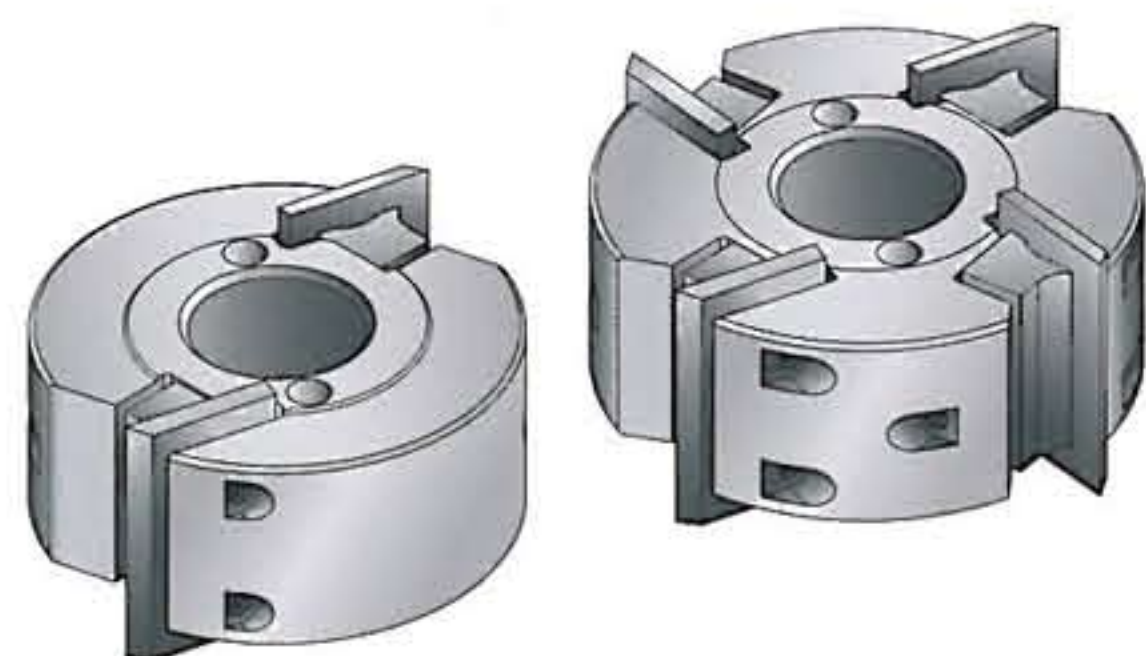

TWO CUTTING ANGLES ON ONE CUTTER

4-knife cutter can be mounted with two different cutting angles of knives, allowing for cutting soft and hard wood.

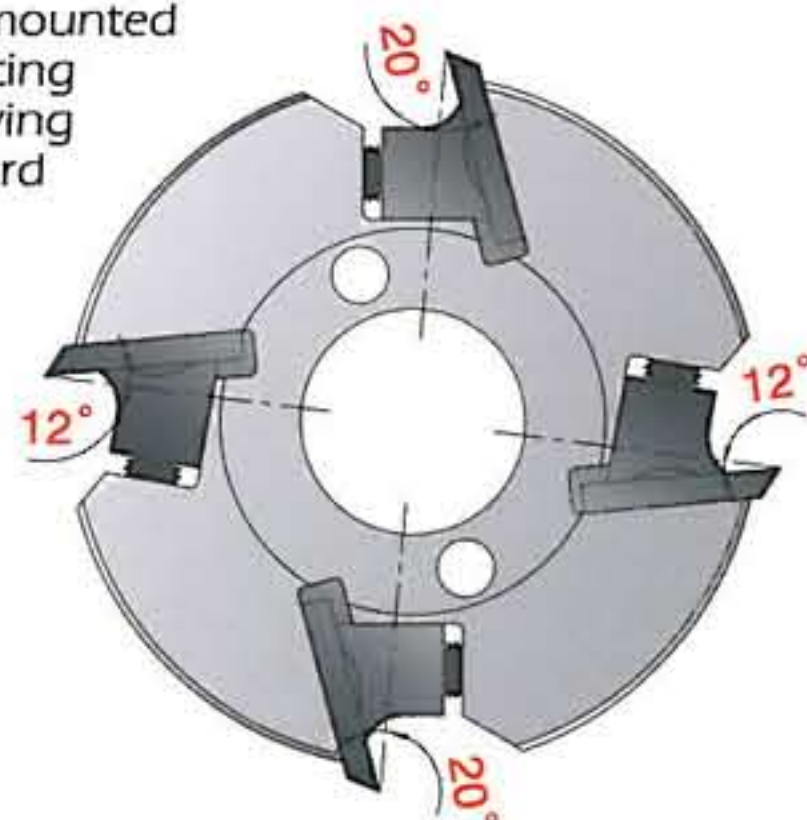

DUST BLOWER (Optional)

- The dust blower is driven by a 3HP motor, single or three phase power.
- Designed with 4 dust suction ports.



Easy mobility (Optional)

- The moulder is equipped with four wheels at the four corners for easy movement by only one person.
- The operator may treadle on the foot plate for raising the machine when moving the machine is required.



C-30HP. / C-40HP. / C-50HP. Automatically Operated Rotary Phase Converter

- Suitable for converting 230V, 1 phase to 230V, 3 phase power.
- Multiple motor control within the 95% of the rated horsepower.

MODEL	NANE PLATE LOAD
C-30HP	30HP
C-40HP	40HP
C-50HP	50HP

Permissible Load 95%

PROFIED KNIFE GRINDER (Optional)

- Designed for grinding the profile of knife.
- Profile is reproduced by an acrylic template.
- Equipped with one diamond dresser.



UNIVERSAL KNIFE GRINDER (Optional)

- Designed for sharpening straight knife and profile knife.
- Foot switch control for convenience.



CKM[®]
Quality & Service

Profile Knives :

CKM provides an extraordinary selection of high quality profile knives to meet your specific requirements.

TONGUE & GROOVE

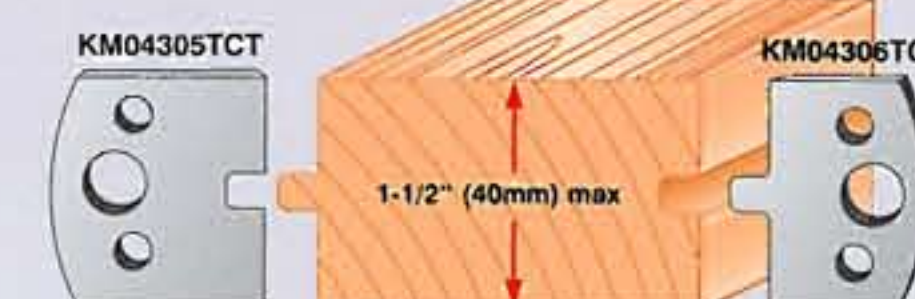

STUDS AND PLANKS

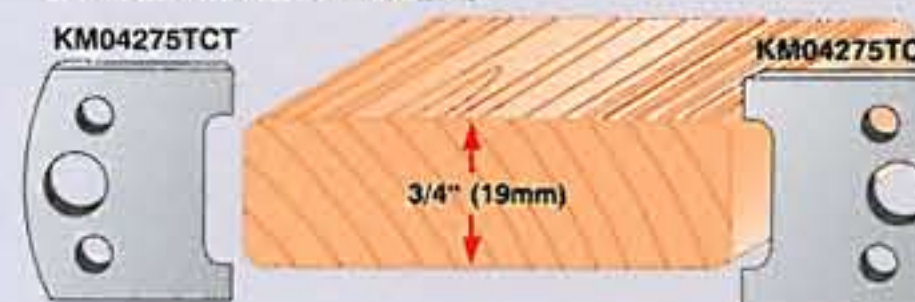

PANELING & SIDING

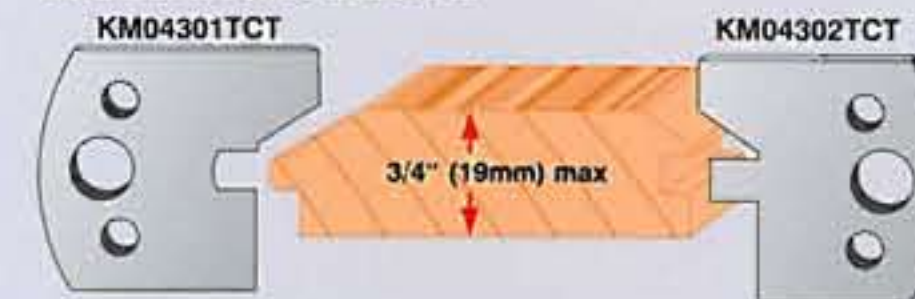

PANELING & SIDING

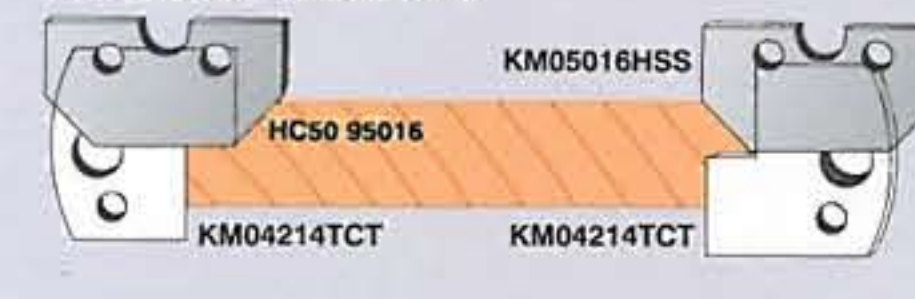

PANELING & SIDING

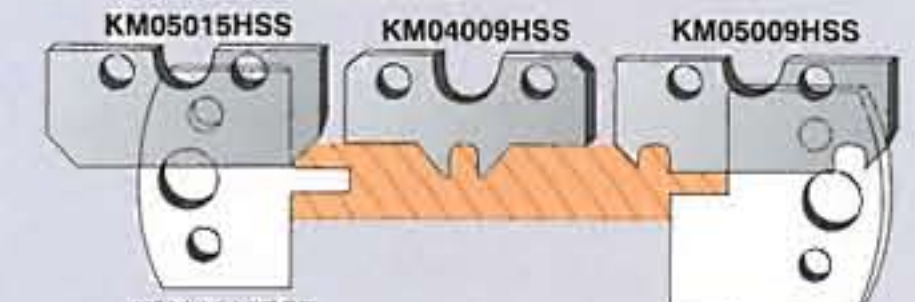

PANELING & SIDING

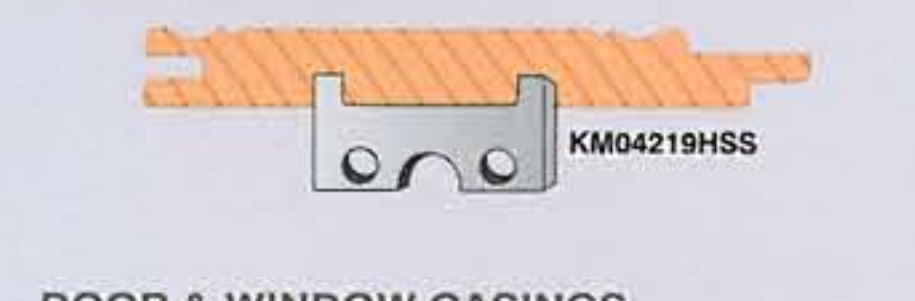

DOOR & WINDOW CASINGS

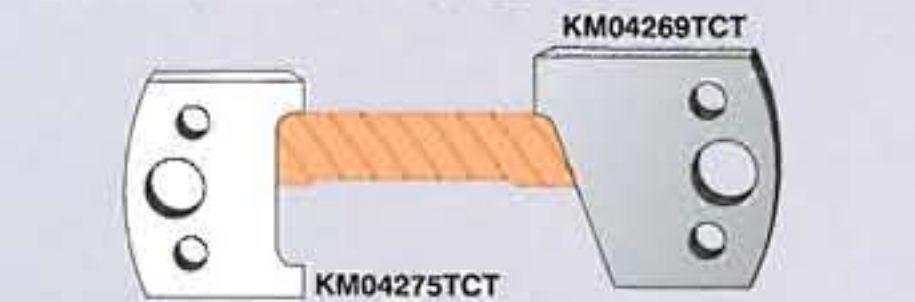

DOOR & WINDOW CASINGS



DOOR & WINDOW CASINGS



DOOR & WINDOW CASINGS

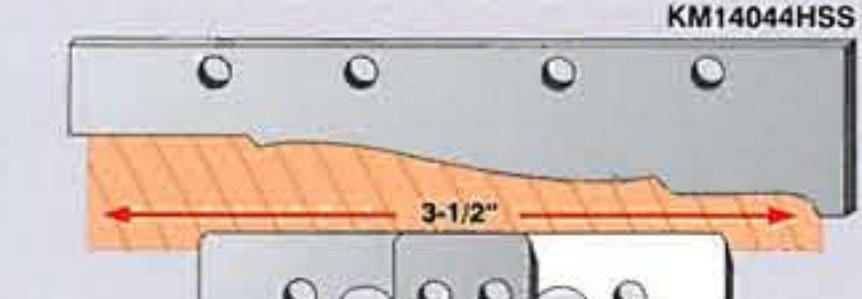

DOOR & WINDOW CASINGS



BASEBOARD MOULDINGS

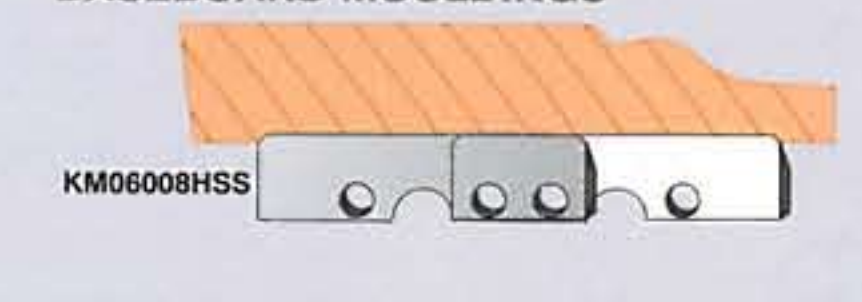

CROWN MOULDINGS

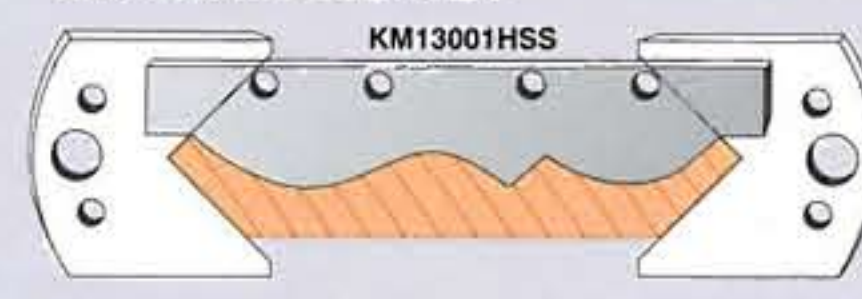

CROWN MOULDINGS

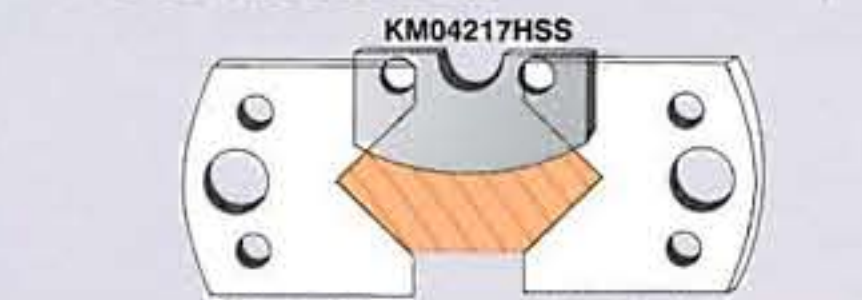

QUARTER ROUND

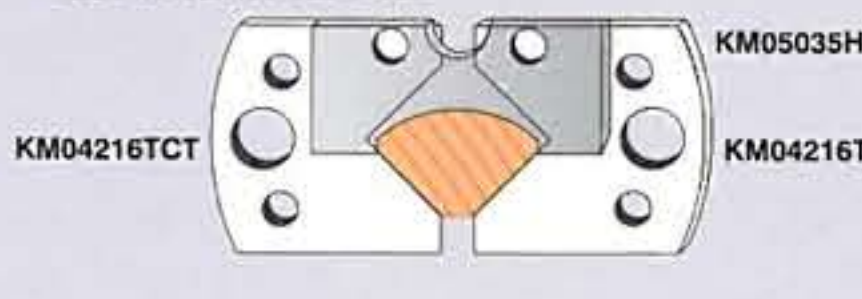

QUARTER ROUND

